

LINEAR INTEGRATED CIRCUITS

DESCRIPTION

The 540 is a monolithic, class AB power amplifier designed specifically to drive a pair of complementary output transistors. The device features low standby current yet retains a high output current drive capability with internal current limiting. A wide power bandwidth and excellent linearity make this device ideal for use as an audio power amplifier.

FEATURES

- INTERNAL CURRENT LIMITING
- LOW STANDBY CURRENT
- HIGH OUTPUT CURRENT CAPABILITY
- WIDE POWER BANDWIDTH
- LOW DISTORTION

ABSOLUTE MAXIMUM RATINGS

Supply Voltage	± 27 Volts SE540
	± 22 Volts NE540
Operating Temperature Range	-55°C to +125°C SE540
	0°C to +70°C NE540
Storage Temperature Range	-65°C to +150°C
Output Short Circuit Duration	Indefinite
(Not exceeding maximum dissipation.)	

PIN CONFIGURATION

L PACKAGE
(Top View)

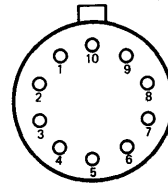

1. Power Limit
2. Non Inverting Input
3. NC
4. Inverting Input
5. Power Limit
6. V⁻
7. Output 1 (emitter)
8. Output 2 (base)
9. Output 3 (collector)
10. V⁺

ORDER PART NOS. SE540L/NE540L

SCHEMATIC DIAGRAM

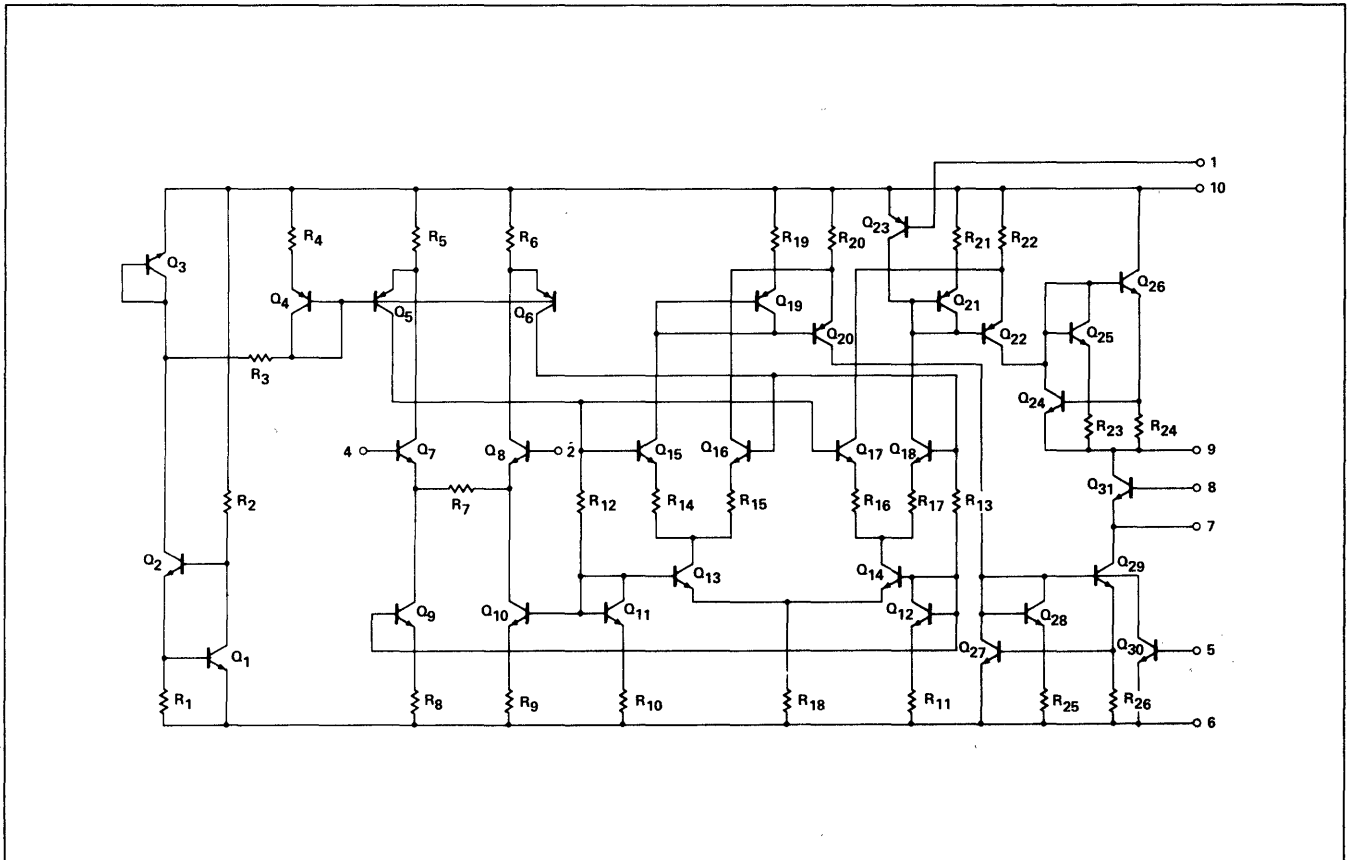

SIGNETICS ■ SE/NE 540L – POWER DRIVER

ELECTRICAL CHARACTERISTICS ($T_A = 25^\circ\text{C}$ unless otherwise specified)

PARAMETER	TEST CONDITIONS	SE 540			NE 540			UNIT
		MIN	TYP	MAX	MIN	TYP	MAX	
Operating Temperature Range		-55		+125	0		+70	°C
Operating Supply Voltage		±5		±25	±5		±20	Volts
Quiescent Current			13	20		13	20	mA
Input Offset Voltage			5	7		7	10	mV
Input Offset Current			0.3	0.7		0.5	1	μA
Input Bias Current			1.5	3		2	5	μA
Input Impedance	40 dB Gain		20			20		kΩ
Current Gain		80	100		70	90		dB
Gain Variation Over Temperature Range	40 dB Gain		±0.1			±0.1		dB
Frequency Response	40 dB Gain ±1 dB		500			100		kHz
Distortion	40 dB Gain Output 3 dB below maximum $R_L = 600\Omega$		0.25	0.5		0.5	1.0	%
Equivalent Input Noise Voltage	$R_S = 600\Omega$ 50 Hz to 500 kHz		10			10		μV
Power Supply Rejection Ratio	40 dB Gain	80	90		60	80		dB
Common Mode Rejection Ratio			110			90		dB
Output Drive Current		±120	±150		±80	±100		mA
Slew Rate	$V_S = \pm 20V$ $V_{OUT} = \pm 15V$		200			200		V/μs

TEST CIRCUITS

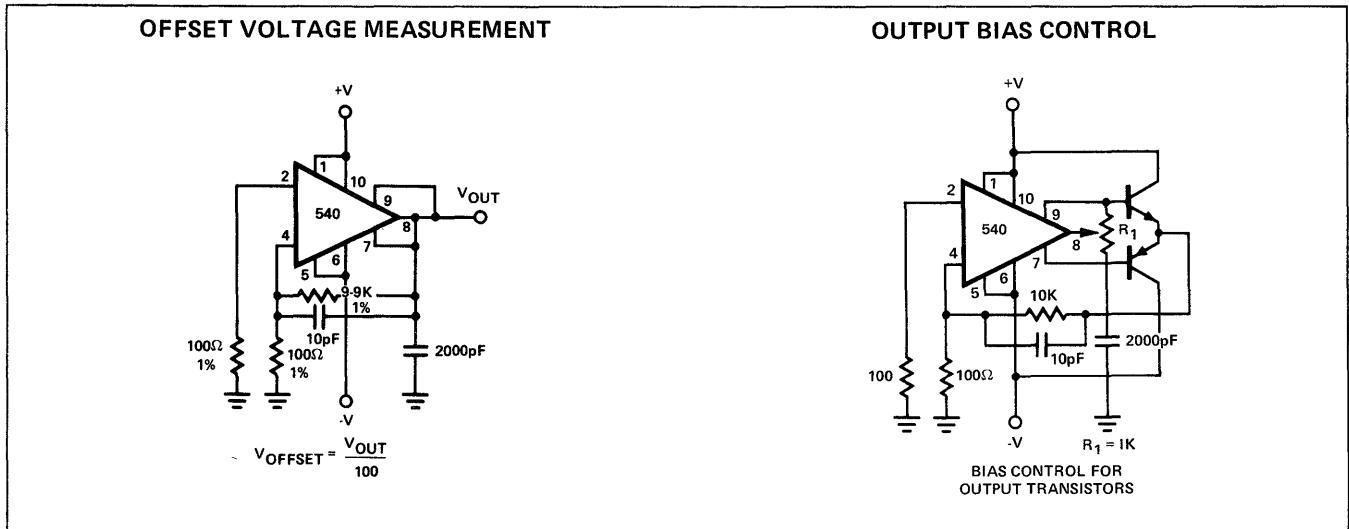

TYPICAL PERFORMANCE CHARACTERISTICS

CLOSED LOOP FREQUENCY RESPONSE

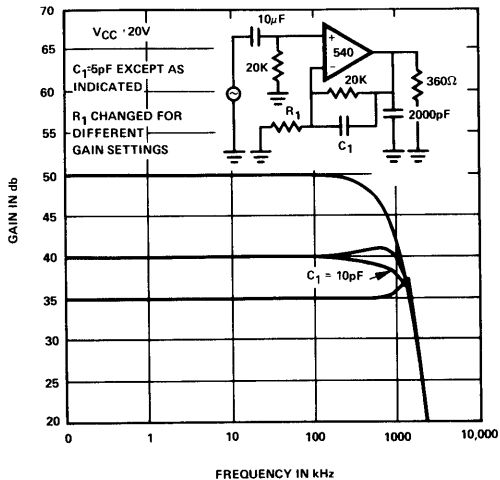

OPEN LOOP GAIN AND FREQUENCY RESPONSE

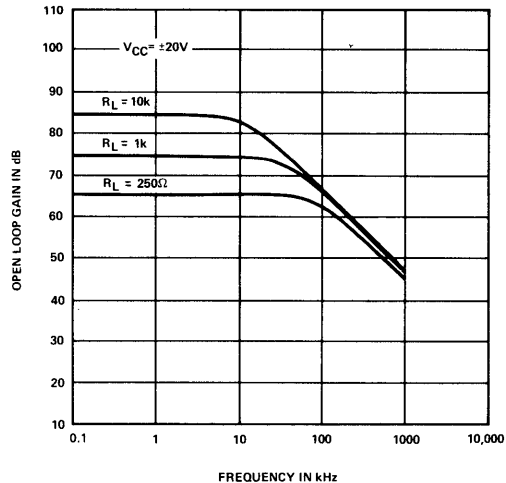

PHASE RESPONSE VERSUS FREQUENCY

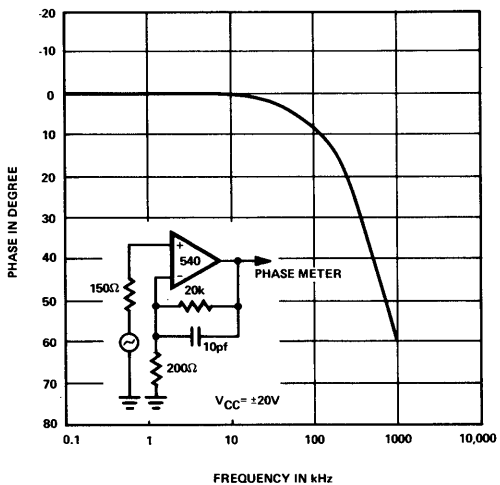

POWER SUPPLY REJECTION VERSUS FREQUENCY

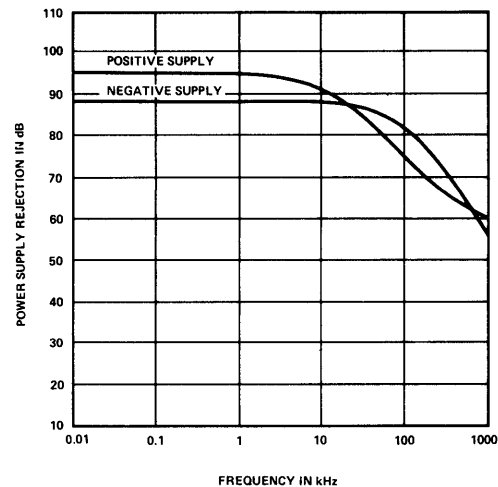

OUTPUT CURRENT VERSUS IB/VBE OF CURRENT LIMITER

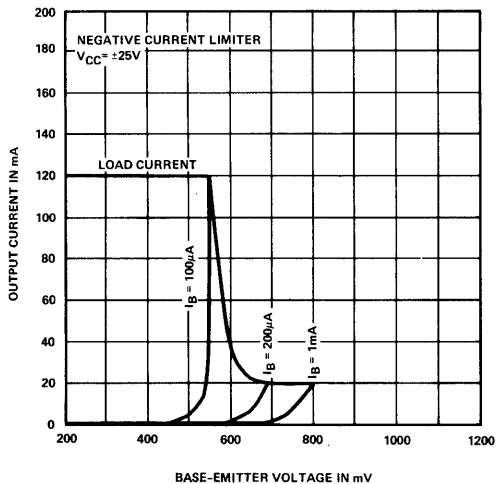

OUTPUT CURRENT VERSUS IB/VBE OF CURRENT LIMITER

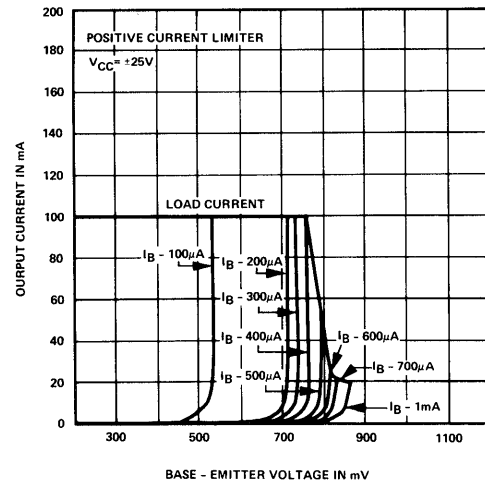

TYPICAL PERFORMANCE CHARACTERISTICS (Cont'd.)

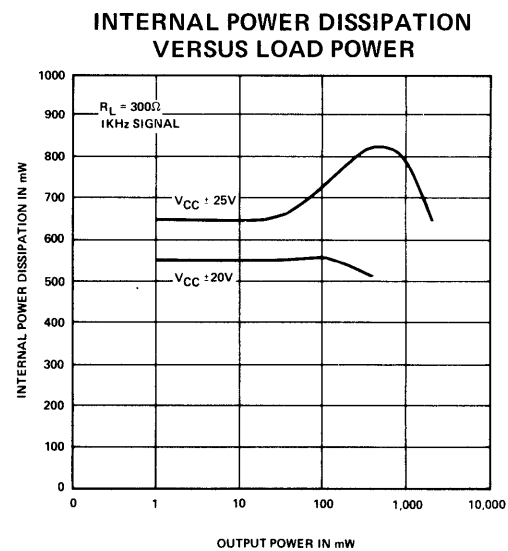
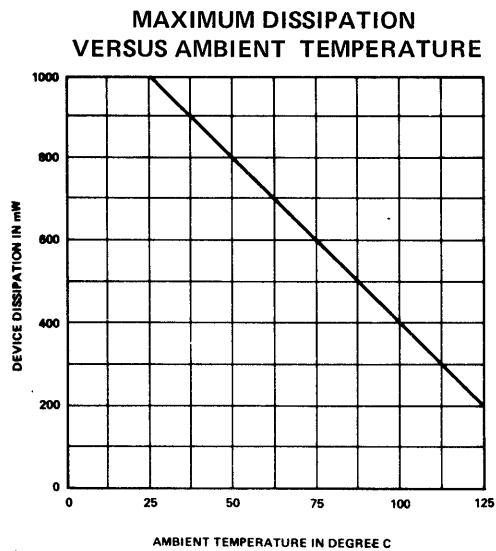
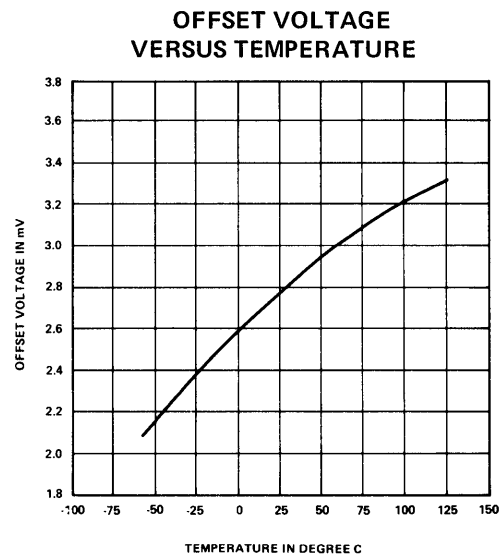
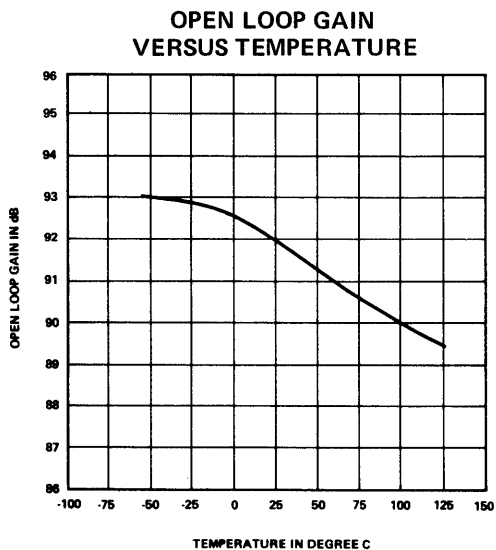
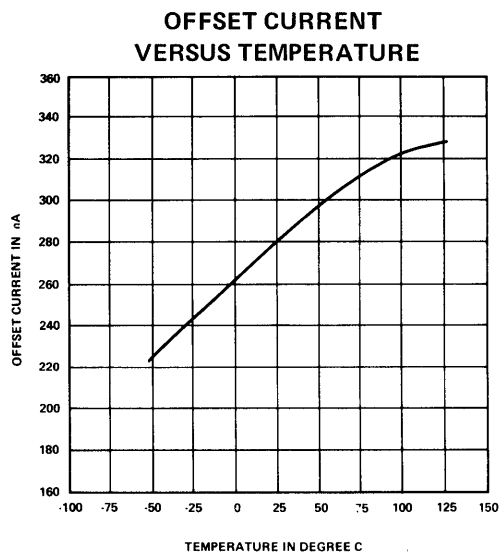
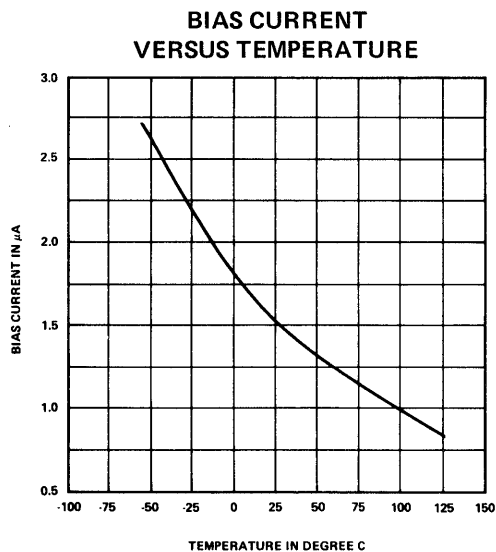

TYPICAL PERFORMANCE CHARACTERISTICS (Cont'd.)

QUIESCENT CURRENT
VERSUS SUPPLY VOLTAGE

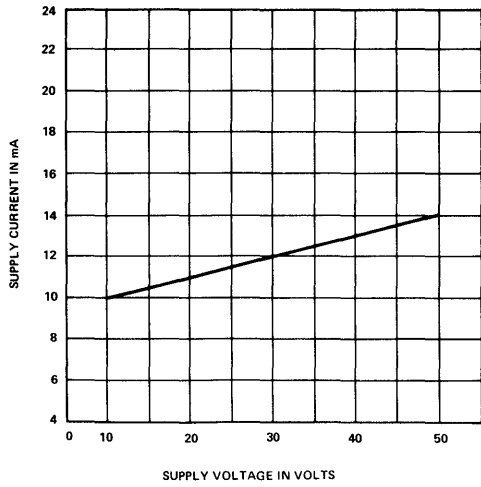

TOTAL HARMONIC DISTORTION
VERSUS OUTPUT

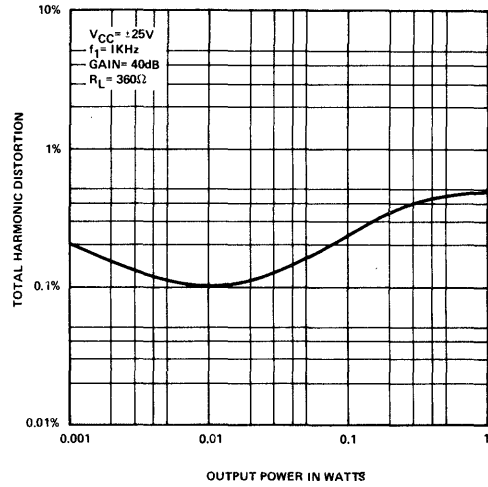

OUTPUT SATURATION VOLTAGE
VERSUS LOAD

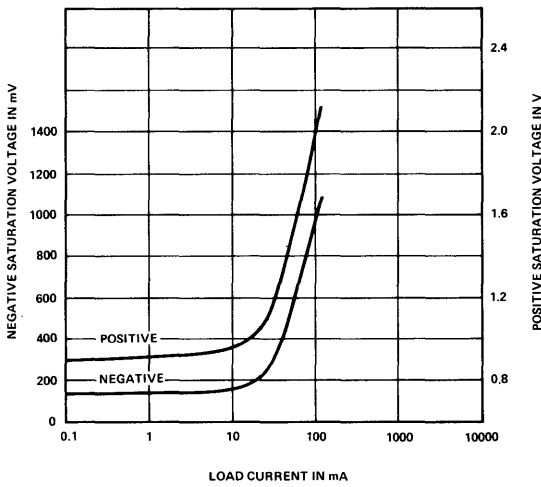

TOTAL HARMONIC DISTORTION
VERSUS FREQUENCY

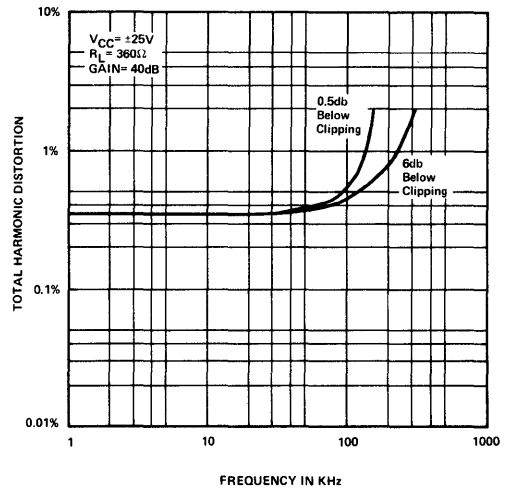

INTERMODULATION DISTORTION
VERSUS LOAD

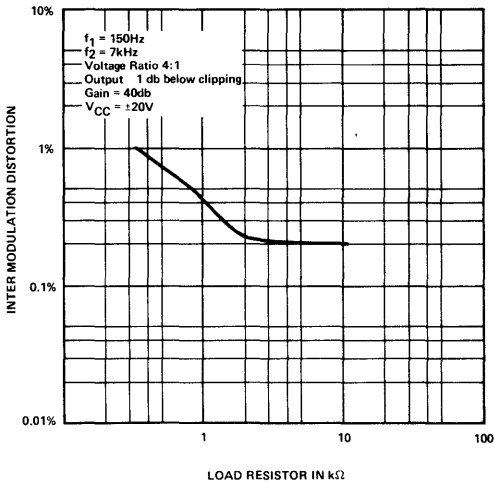

TOTAL HARMONIC DISTORTION
VERSUS LOAD

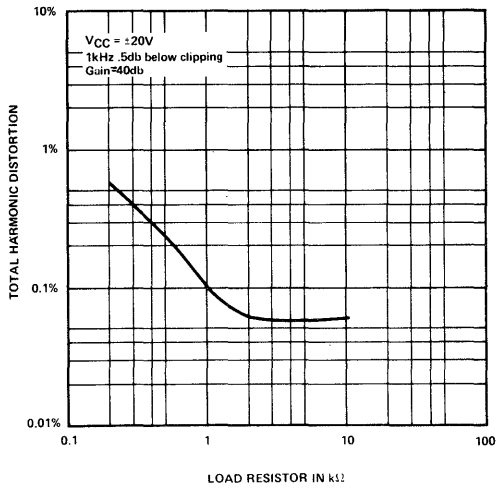

POSITIVE VOLTAGE REGULATORS

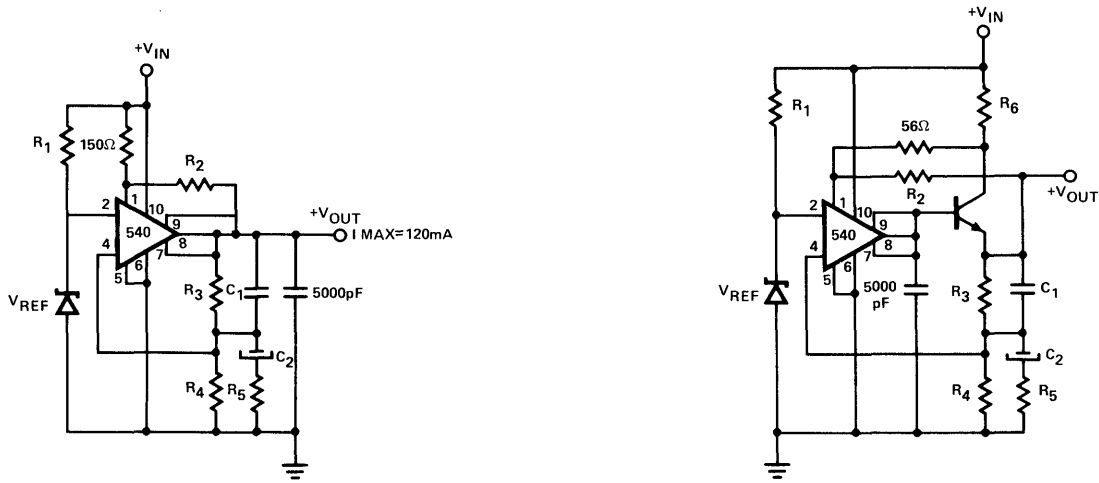

$$V_{OUT} \approx \frac{R_3 + R_4}{R_4} V_{REF}$$

$$R_1 \approx \frac{V_{IN} \cdot V_{REF}}{I_{ZENER}}$$

$$R_2 \approx \frac{2 V_{IN} \cdot V_{OUT}}{4mA}$$

$$R_5 \approx \frac{R_3}{100}$$

$$C_1 \approx \frac{0.2}{R_3} \mu F$$

$$C_2 \approx 10 \mu F$$

NEGATIVE VOLTAGE REGULATORS

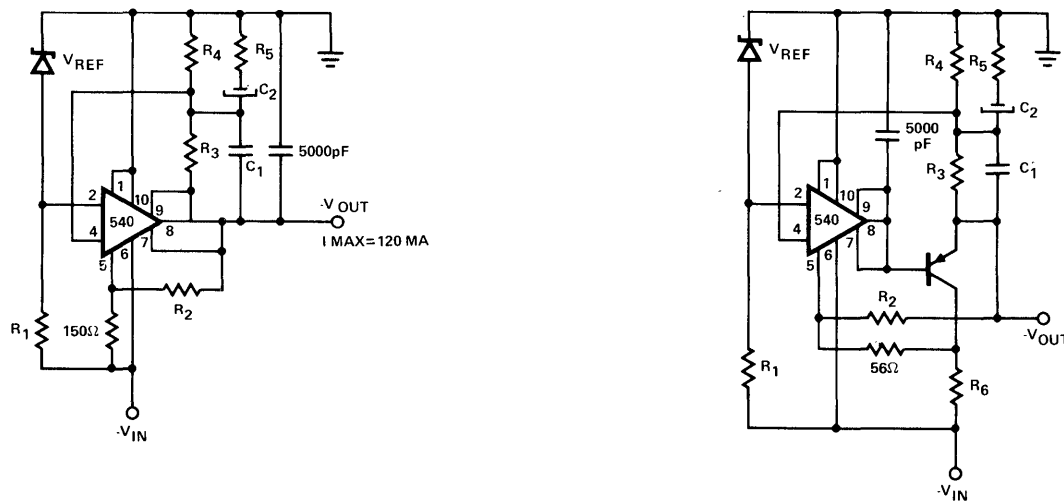

$$V_{OUT} \approx \frac{R_3 + R_4}{R_4} V_{REF}$$

$$R_1 \approx \frac{V_{IN} \cdot V_{REF}}{I_{ZENER}}$$

$$R_2 \approx \frac{2 V_{IN} \cdot V_{OUT}}{4mA}$$

$$R_5 \approx \frac{R_3}{100}$$

$$C_1 \approx \frac{0.2}{R_3} \mu F$$

$$C_2 \approx 10 \mu F$$

TYPICAL APPLICATIONS

POWER AMPLIFIERS

1 Watt

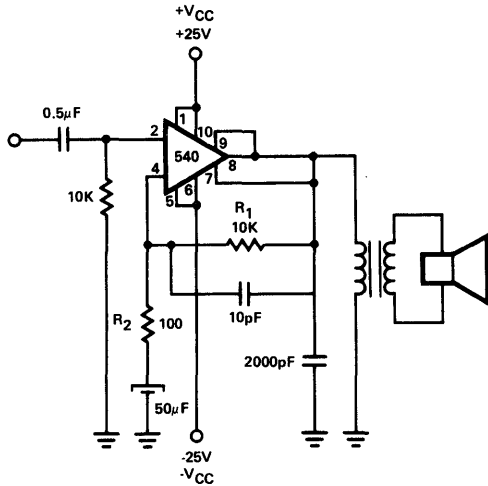

VOLTAGE GAIN
 $A_V \approx \frac{R_1 + R_2}{R_2}$

35 Watts

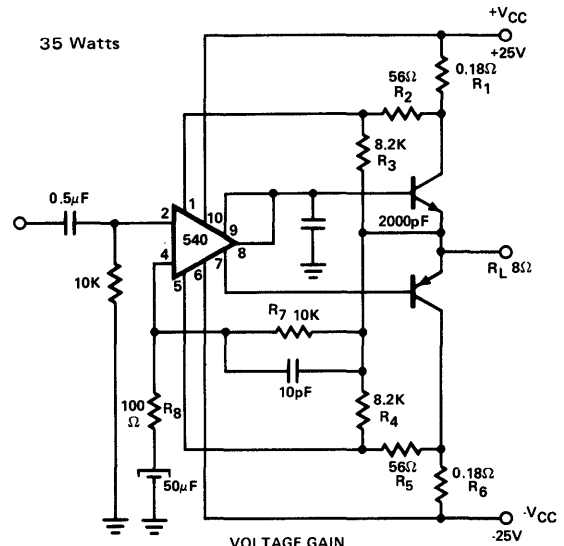

VOLTAGE GAIN
 $A_V = \frac{R_7 + R_8}{R_8}$
 CURRENT LIMITING
 $R_1 = R_6 \approx \frac{650mV}{I_{peak}}$
 POWER LIMITING
 $R_2 = R_5 \approx 56\Omega$
 $R_3 = R_4 \approx 3mA$

3 Watts

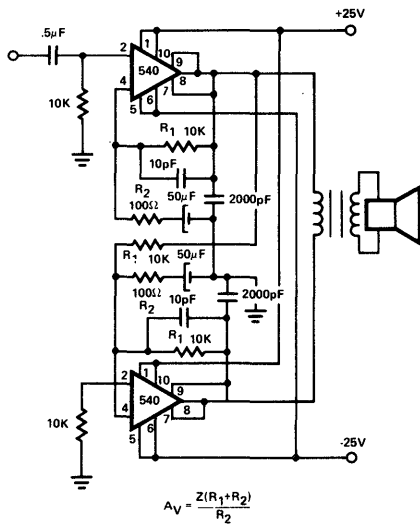

$A_V = \frac{2(R_1 + R_2)}{R_2}$

70 Watts

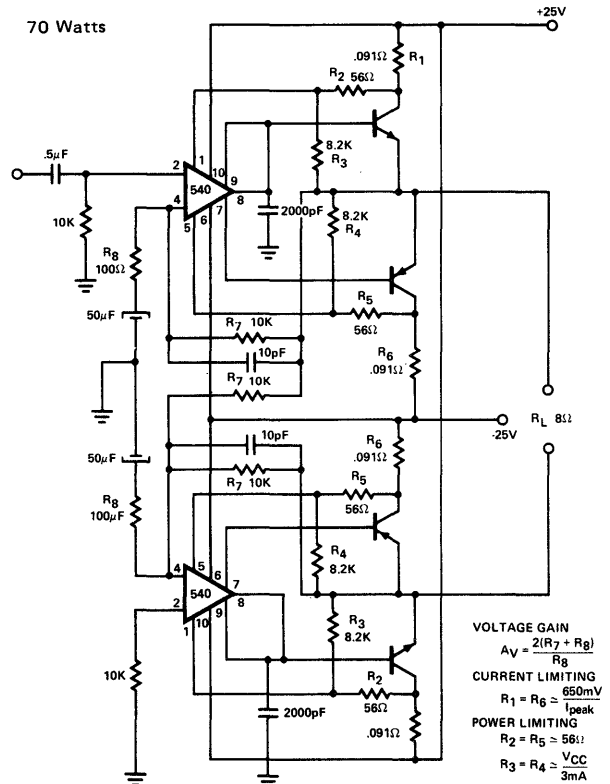

VOLTAGE GAIN
 $A_V = \frac{2(R_7 + R_8)}{R_8}$
 CURRENT LIMITING
 $R_1 = R_6 \approx \frac{650mV}{I_{peak}}$
 POWER LIMITING
 $R_2 = R_5 \approx 56\Omega$
 $R_3 = R_4 \approx 3mA$

35 WATT AMPLIFIER

P.C. BOARD LAYOUT (BOTTOM VIEW)

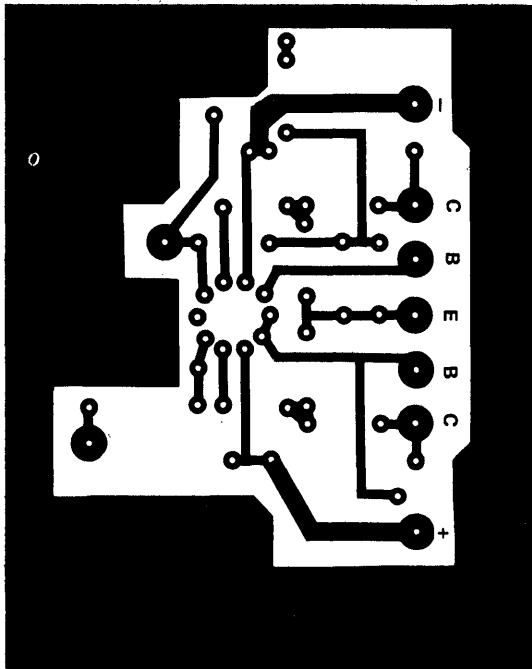

PARTS LAYOUT (TOP VIEW)

