

DESCRIPTION

The LM111 series are voltage comparators that have input currents approximately a hundred times lower than devices like the μ A710. They are designed to operate over a wider range of supply voltages; from standard $\pm 15V$ op amp supplies down to the single 5V supply used for IC logic. Their output is compatible with RTL, DTL, and TTL as well as MOS circuits. Further, they can drive lamps or relays, switching voltages up to 50V at currents as high as 50mA.

Both the inputs and the outputs of the LM111 series can be isolated from system ground, and the output can drive loads referred to ground, the positive supply or the negative supply. Offset balancing and strobe capability are provided and outputs can be wire OR'ed. Although slower than the μ A710 (200ns response time vs 40ns) the devices are also much less prone to spurious oscillations. The LM111 series has the same pin configuration as the μ A710 series.

The LH2111 series hybrids are 2 LM111 type comparators in one hermetic package. They feature the same electrical parameters as the single devices.

FEATURES

- Operates from single 5V supply
- Maximum input bias current: 150nA (LM311 - 250nA)
- Maximum offset current: 20nA (LM311 - 50nA)
- Differential input voltage range: $\pm 30V$
- Power consumption: 135mW at $\pm 15V$
- High sensitivity—200V/mV
- Military qualification pending
- LH2111 offers close thermal tracking

PIN CONFIGURATIONS

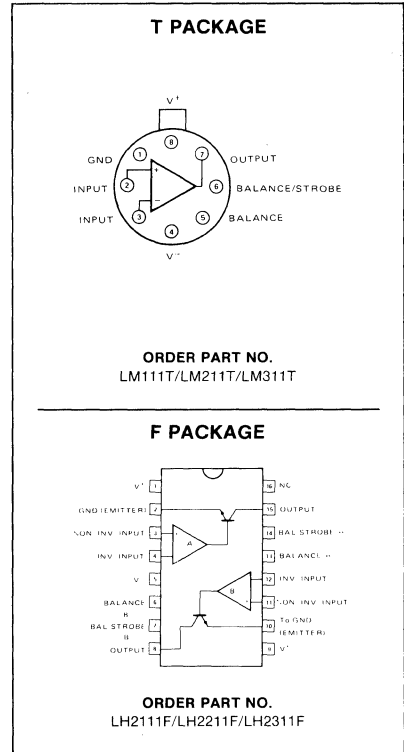
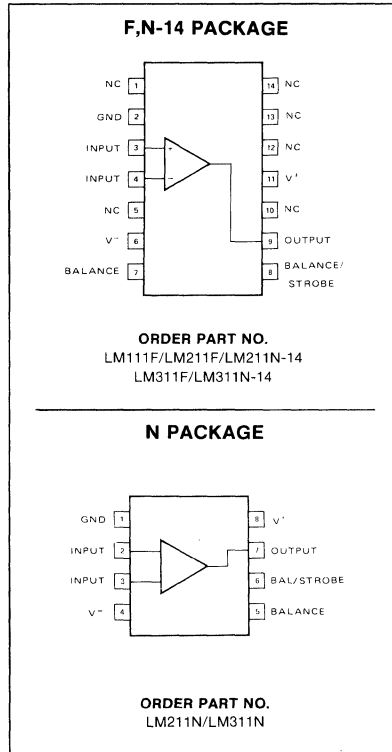

EQUIVALENT SCHEMATIC

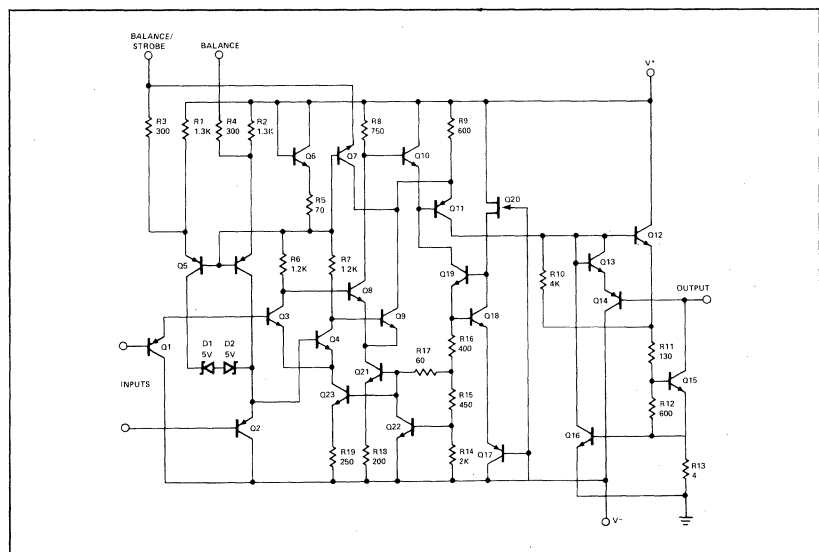

ABSOLUTE MAXIMUM RATINGS

PARAMETER	RATING	UNIT
Total supply voltage	36	V
Output to negative supply voltage:		
LM111/LM211, LH2111/LH2211	50	V
LM311, LH2311	40	V
Ground to negative supply voltage	30	V
Differential input voltage	±30	V
Input voltage ¹	±15	V
Power dissipation ²	500	mW
Output short circuit duration	10	sec
Operating temperature range		
LM111, LH2111	-55 to +125	°C
LM211, LH2211	-25 to +85	°C
LM311, LH2311	0 to +70	°C
Storage temperature range	-65 to +150	°C
Lead temperature (soldering, 10sec)	300	°C

DC ELECTRICAL CHARACTERISTICS 1,2,3

PARAMETER	TEST CONDITIONS	LM111/LM211/LH2111/LH2211			LM311/LH2311			UNIT
		Min	Typ	Max	Min	Typ	Max	
Input offset voltage ⁴	T _A = 25°C, R _S ≤ 50kΩ		0.7	3.0		2.0	7.5	mV
Input offset current ⁴	T _A = 25°C		4.0	10		6.0	50	nA
Input bias current	T _A = 25°C		60	100		100	250	nA
Voltage gain	T _A = 25°C		200			200		V/mV
Response time ⁵	T _A = 25°C		200			200		ns
Saturation voltage	V _{IN} ≤ -5mV, I _{OUT} = 50mA T _A = 25°C		0.75	1.5		0.75	1.5	V
Strobe on current	T _A = 25°C		3.0			3.0		mA
Output leakage current	V _{IN} ≥ 5mV, V _{OUT} = 35V T _A = 25°C, I _{STROBE} = 3mA		0.2	10		0.2	50	nA
Input offset voltage ⁴	R _S ≤ 50kΩ			4.0			10	mV
Input offset current ⁴				20			70	nA
Input bias current				150			300	nA
Input voltage range			±14			±14		V
Saturation voltage	V ₊ ≥ 4.5V, V ₋ = 0 V _{IN} ≤ -6mV, I _{SINK} ≤ 8mA		0.23	0.4		0.23	0.4	V
Output leakage current	V _{IN} ≥ 5mV, V _{OUT} = 35V		0.1	0.5				μA
Positive supply current	T _A = 25°C		5.1	6.0		5.1	7.5	mA
Negative supply current	T _A = 25°C		4.1	5.0		4.1	5.0	mA

NOTES

1. This rating applies for ±15V supplies. The positive input voltage limit is 30V above the negative supply. The negative input voltage limit is equal to the negative supply voltage or 30V below the positive supply, whichever is less.
2. The maximum junction temperature of the LM311, LH2311 is 110°C. For operating at elevated temperatures, devices in the TO-5 package must be derated based on a thermal resistance of 150°C/W, junction to ambient, in the N package, a thermal resistance of 162°C/W, and °C/W for the Ceramic package. The maximum junction temperature of the LM111, LH2111 is 150°C, while that of the LM211, LH2111 is 110°C. For operating at elevated temperatures, devices in the TO-5 package must be derated based on a thermal resistance of 150°C/W, junction to ambient. The thermal resistance of the Cerdip package is 110°C/W, junction to ambient.
3. These specifications apply for V_S = ±15V and 0°C < T_A < 70°C unless otherwise specified. With the LM211, LH2111 however, all temperature specifications are limited to -25°C ≤ T_A ≤ 85°C and for the LM111 and LH2111 are limited to -55°C < T_A < 125°C. The offset voltage, offset current and bias current specifications apply for any supply voltage from a single 5V supply up to ±15V supplies.
4. The offset voltages and offset currents given are the maximum values required to drive the output within a volt of either supply with 1mA load. Thus, these parameters define an error band and take into account the worst case effects of voltage gain and input impedance.
5. The response time specified (see definitions) is for a 100mV input step with 5mV overdrive.

TYPICAL APPLICATIONS

