

3mm, Flat Top LED CBI® Circuit Board Indicator In-line, 3 Leaded Bi-Color

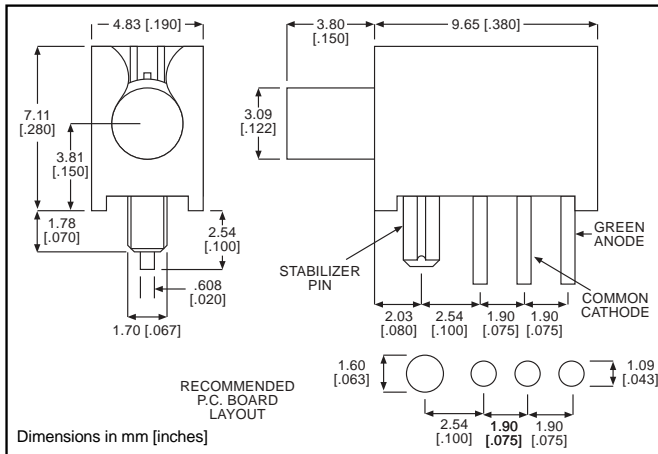

551-3508



PART NO.

551-3508

COLOR

Red/Green

Features

- Common Cathode simplifies design, and provides amber as a third color
- Locating pin provides stability during soldering
- Multiple CBIs form horizontal LED arrays on 4.2mm (0.1650") center-lines
- High Contrast, UL 94 V-0 rated, black housing
- Oxygen index: 31.5%
- Polymer content: PBT, 1.055 g
- Housing stand-offs facilitate PCB cleaning
- Solderability per MIL-STD-202F, method 208F
- LEDs are safe for direct viewing per IEC 825-1, EN-60825-1

Tolerance note: As noted, otherwise:

- LED Protrusion: ± 0.04 mm [± 0.016]
- CBI Housing: ± 0.02 mm [± 0.008]

Typical Operating Characteristics ($T_A=25^\circ\text{C}$)

See LED data sheet for additional information

See page 4-70 and 4-71 for Reference Only LED Drive Circuit Examples. See page 4-72 for Pin Out

Part Number	Color	Peak Wavelength nm	I _v mcd	V _F Volts	Test Current (mA)	LED Data sheet	Page #
551-3508	Red/Green	630/560	4/4	2/2.1	20	3TF-9484	4-69

4